

OPTIMIZED ENGINE OUT PROCEDURES
FOR MULTI ENGINE AIRPLANES

Melville R. Byington, Jr.
Aeronautical Science Department
Embry Riddle Aeronautical University
Daytona Beach, FL 32014

Abstract

This investigation examined hazards associated with asymmetric thrust, engine out flying in twin engine airplanes at low speeds and low altitudes. National Transportation Safety Board (NTSB) data provided a measure of the comparative risks posed by control and performance inadequacies.

Pilot training literature, as well as both pilot and instructor levels of awareness, indicated considerable misunderstanding of relevant aerodynamic principles. Virtually total emphasis has been devoted to directional control, which represents but one-third of the hazard. Regardless of circumstances, five degrees of bank is commonly believed to be the best available procedure for engine out flight.

Mathematical analysis has been used to show that the optimum performance bank angle depends on several factors. In marginal rate of climb scenarios, the optimum bank is much smaller than five degrees. Wind tunnel experiments validated the analytical work and suggested substantially improved climb performance was achievable, with adequate control, by flying at zero sideslip.

Flight tests in three light twin airplane models verified that angle of bank strongly influences rate of climb. Best climb resulted at the small angles of bank corresponding to zero sideslip. Increasing bank to five degrees degraded climb performance approximately 75-90 feet per minute from optimum. This penalty was equivalent to a weight addition of up to nine percent or a density altitude increase of as much as 1900 feet.

Pilot Operator Handbook predicted rate of climb was achieved only at zero sideslip.

Engine-out training techniques incorporating correct aerodynamic principles have been recommended. Similarly, appropriate revisions to The Federal Aviation Administration (FAA) Flight Training Handbook (FAA, 1980) and other training references are proffered.

"A false notion which is clear and precise will always have more power in the world than a true principle which is obscure or involved" (anonymous).

Introduction

Since the advent of twin-engine airplanes, the rhetorical question has been asked whether that second engine makes the plane twice as safe or twice as dangerous? The answer depends on the pilot's knowledge and training. The more complex plane demands more decisions and provides less margin for error, particularly during engine-out emergencies.

The literature and airplane mishap records suggest potential for significant improvement. Unpublished National Transportation Safety Board (NTSB) data for light twin accidents between March 1984 and October 1986 was examined. It indicated that an annual average of 33 accidents occurred in the initial climb (between liftoff and power reduction) phase of engine-out flight. Evaluating accident narratives, the investigator rejected approximately 70% which appeared due to weather, fuel mismanagement, other gross judgement or technique deficiencies, or which otherwise defied classification. The remaining 23 (nine per year) could be attributed to: (a) loss of directional control, (b) stall, or (c) inadequate climb performance. The resulting distribution of causal factors for these three is contained in Table 1.

Table 1Light Twin Engine-out Initial Climb Accident Factors

CAUSE	Accidents (%)	Fatal/Serious Injury (%)
Loss of Direct. Cont.	30%	35%
Stall/Spin	26%	38%
Inadequate Climb Perf.	43%	25%

A review was conducted of pilot-oriented literature relating to handling engine-out emergencies. It indicated that certain dubious concepts are widespread in the pilot training and certification process. Extensive written questioning of pilots proved such to be the case. Virtually all engine-out training emphasis is focused on directional control, whereas inability to maintain altitude and/or airspeed causes two-thirds of the accidents and injuries.

Aviation educators and organizations such as the University Aviation Association may consider it appropriate to assert a leadership role in clarifying questions related to engine-out flying. It is in hope of correcting certain common misconceptions that this treatise is aimed.

Significance

The following analysis deals with optimum management of the engine-out situation in conventional, wing-mounted, twin-engine airplane wherein yaw from asymmetrical thrust can be substantial. Extension to three or four engine airplanes would be straightforward.

Analysis of forces and moments

**FIGURE 1: RIGHT ENGINE INOPERATIVE
(wings level, ball centered)**

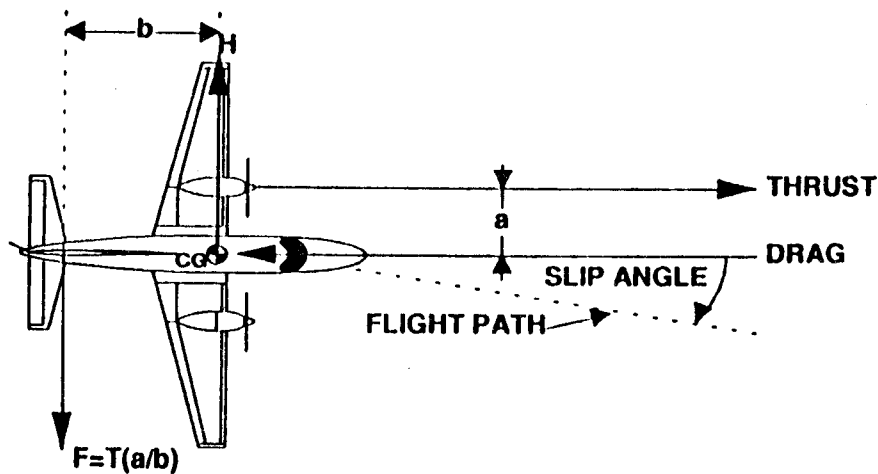

Figure 1 depicts the asymmetric, engine out flight conditions resulting from a failed (right) engine. The airplane is assumed configured for climb, with propeller feathered. Clockwise yaw due to the engine thrust T offset by distance a is neutralized by (left) rudder deflection. The drag D is assumed to equal T and act through the center of gravity (CG). To counteract yaw due to asymmetric thrust, the lateral tail force F must equal $T(a/b)$, where b is the longitudinal distance between the CG and tail's aerodynamic center. Acting through the vertical tail's aerodynamic center, it produces a counter clockwise moment equal to $T(a)$. The plane must sideslip (to the right) such that a horizontal fuselage lift force H , equal and opposite to F and assumed to act through the CG, is established.

Level, equilibrium flight at zero angle of bank would then prevail. The balance ball would be centered, and all would appear tidy from the cockpit. In fact, until approximately 1980, many pilots were trained to fly, engine-out, in just this manner.

Disadvantages of the sideslip are twofold, since "sideways" flight inevitably:

1. increases drag, and
2. decreases the tail fin's angle of attack, thereby adding a weathervaning tendency which compounds the yaw from asymmetric thrust.

Both climb performance and directional control are degraded by sideslip toward the inoperative engine. Current literature seems unanimous on that point.

Since the plane is slipping with wings level, can one bank the opposite direction (toward the operative engine) to alleviate both the disadvantages cited? As will be proven, the answer is yes, but only up to a point. Furthermore, one must become familiar with the governing laws of physics.

The optimum amount of bank angle, into the operative engine, is the key question. It is central to how multi-engine emergency training is conducted and how unquestioning multi-engine pilots inculcate their emergency procedures. Unfortunately, evidence suggests much of that training is incomplete or incorrect. Various items of evidence will be examined to evaluate the current state of pilot training and opinion on this subject, together with speculation as to the confusion's root cause.

Questionnaire results

The following written question, among several others, was administered to all multi-engine rated pilots at a Certified Flight Instructor (CFI) refresher seminar and at a Federal Aviation Administration (FAA) safety seminar.

"With regard to engine-out flying, select the following statement you consider most correct.

- a. Best climb performance and directional control are achieved at zero bank angle.
- b. Best climb performance results from the bank producing zero sideslip. Additional bank improves directional control but hurts performance.
- c. Best directional control results from the bank producing zero sideslip. Additional bank improves performance but hurts directional control.
- d. The bank angle producing zero sideslip results both in best performance and directional control.
- e. A five degree bank gives the best performance and directional control.
- f. A bank angle of more than five degrees gives best performance and directional control.
- g. None of the above statements is correct".

Only 26% of an experienced, representative cross section of 54 multi-engine pilots (including just 22% of the multi-engine instructors) answered correctly. Significantly, 78% of the wrong responses were choice "e". The investigator termed this

phenomenon the Five Degree Forever (FDF) Syndrome, and it will be analyzed carefully. As will be proven, five degrees of bank provides neither best performance nor best directional control.

Literature Review

In his pioneering work, Berven (1980) focused on the influence of bank on the relationship between an airplane's published and actual minimum control speed (V_{mc}). He pointed out that Federal Aviation Regulation 23.149a defines the precise conditions under which the manufacturer must determine V_{mc}, and permits the applicant an angle of bank of not more than five degrees. Since greater bank yields a lower, more favorable V_{mc}, the clear intent of the Regulation is to impose standardization, limit the permissible bank, and preclude publication of unrealistic V_{mc} values.

Berven emphasized that the actual V_{mc} may dangerously exceed the nominal value under some scenarios, and that this fact must be understood by multi-engine pilots. Among his most important recommendations to the FAA were that emphasis should be placed both on teaching pilots the importance of banking at least 5° into the good engine immediately after an engine failure, and the correct technique for flying at zero sideslip to maximize engine-out performance and insure optimum stall characteristics.

All evidence suggests that the 5° bank recommendation has received far more emphasis than has the necessity to assume zero sideslip for optimum performance. Furthermore, the relationship

between the two is not well understood by the multi engine pilot and instructor communities.

The current FAA Flight Training Handbook (1980) incorporated part of Berven's recommendations, but failed to clarify the relationship between optimum performance and control. On the contrary, there appears the following assertion:

"Banking at least 5° into the good engine ensures that the airplane will be controllable at any speed above the certificated Vmc, that the airplane will be in a minimum drag configuration for best climb performance, and that the stall characteristics will not be degraded. Engine-out flight with the ball centered is never correct...The magnitude of these effects will vary from airplane to airplane, but the principles are applicable in all cases"(p.237). It appears that this assertion, combined with the 5° bank limit of FAR 23.149a, represents the origin of the FDF Syndrome.

Kershner (1985) discussed engine-out flying technique. He recommended "...also to establish the 10° bank into the good engine..."(p.187), for the purpose of establishing a slip to ensure directional control. Subsequently he warned that "asymmetrical flight such as sideslip greatly increases drag and hurts climb performance"(p.187). However, only the most astute reader is likely to synthesize this guidance correctly to determine the optimum bank appropriate for a particular phase of any emergency.

Kershner's suggested training with a yaw string installed has much merit. However, the instructions to "...set up a bank about one ball width into the operating engine and keep the yaw string centered with the rudder" (p.187) deserve clarification.

A contemporary treatise by Newton (1987) has much to recommend it, and represents a comprehensive explanation of engine-out aerodynamics. It too explained the advantages of training with a yaw string. In handling the emergency, Newton logically emphasized first control, then performance. For control, the recommendation was to "...bank the airplane at least (not at most) five degrees into the good engine" (p.74). In subsequently discussing climb, no mention was made of reducing the bank to improve climb performance. The reader surely must assume the intent was to maintain at least 5°.

Cessna T303 Crusader Handbook (1981) stated "Establish bank-5° toward operating engine. Trim tabs--adjust to maintain 5°..."(p.3-6). The Piper PA 44 Seminole Handbook (1978) stated "Trim the aircraft as required and maintain a 3° to 5° bank toward the operating engine. The ball will be 1/2 to 3/4 out for minimum drag"(p.3-12). By contrast, the Beech Baron 58 Handbook (1979) emergency procedures are silent on the subject of engine out bank angle.

Analytical Estimates of Optimum Performance Bank

Pilot answers to the questionnaire confirmed the pervasiveness of the FDF Syndrome. The training literature, originating with the FAA, is persistent in promoting the

impression that the optimum bank angle is five degrees universally.

Given the variety of configurations and apparent relationship between performance and control, it appeared illogical that 5° , or any single angle of bank, could optimize every situation in every airplane. Therefore, an attempt was made to estimate mathematically that bank angle corresponding to zero slip, minimum drag, and best climb performance. Readers possessing more faith than mathematical curiosity are invited to move ahead to the resulting Equations 1 and 2.

**FIGURE 2: ZERO SIDESLIP FLIGHT
(right engine failed)**

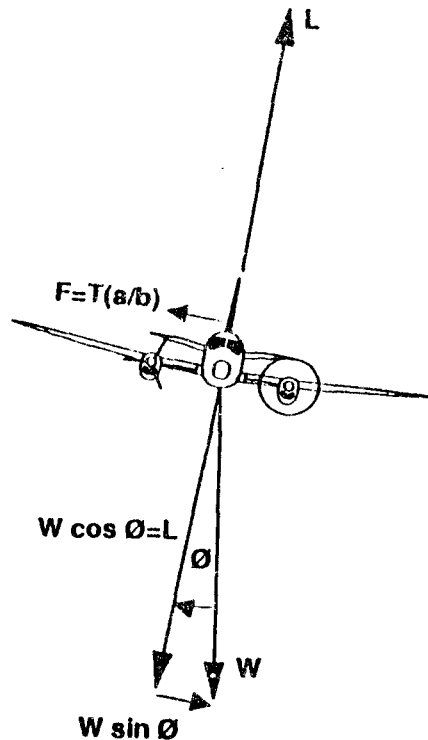

Figure 2 represents a force diagram for (right) engine-out flight in a condition of equilibrium and zero slip. The plane is

banked left at angle O such that the lateral tail force F is just neutralized by the lateral component of weight, $W \sin O$. The sidewise fuselage force H vanishes at zero slip.

From Figures 1 and 2, the tail force, $F=T(a/b)=W \sin O$, or:

$$O=\text{Sin}^{-1}[(T/W)(a/b)] \quad \text{Equation 1}$$

As an item of peripheral interest, the reader is invited to contrast the relationship between weight and lift in normal (symmetrical), level turning flight, with the same relationship in engine-out, non-turning flight. In the former case, the forces are unbalanced and $L=W/\cos O > W$. In the latter case (Figure 2), the forces are balanced and $L=W \cos O < W$. This paradox is explained by the vertical tail's "lift" component ($W \sin^2 O$) opposite to weight. The wing's lift requirement, and induced drag, actually are reduced slightly by virtue of the bank.

Equation 1 established that the zero slip bank angle depends on design geometry (a and b) as well as the thrust to weight ratio. Due to asymmetric disk loading in propeller airplanes, the actual value of distance a depends on which engine is operating, and is greatest with critical engine operations. Distance b varies slightly with CG position. Engineering estimates of the a/b ratio for representative twin-engine airplanes (assuming symmetric disk loading) are contained in Table 2.

From Equation 1, it is important to observe that the thrust to weight ratio (T/W) and required bank angle will be greatest

under conditions of low density altitude and minimum weight. It is under precisely these conditions that performance will be most

Table 2

Twin-Engine Airplane a/b ratios

AIRPLANE	a/b ratio
Cessna Crusader (T 303)	.41
Piper Seminole (PA 44)	.46
Beech Baron 58	.38
Embraer Bandeirante	.35
Boeing 737-200	.39
Lockheed S-3 Viking	.38
Grumman S-2 Tracker	.41
AVERAGE	.40

robust, with maximum tolerance for imprecision. On the contrary, low T/W, marginal climb performance conditions concurrently:

1. present the greatest hazard, and
2. require the minimum bank angle.

An airplane can maintain equilibrium climb only when thrust exceeds drag. The critical, limiting case will be examined wherein thrust just equals drag at zero rate of climb. Lift is assumed equal to weight.

Equation 1 may be modified, using the above assumptions that: $L=W$ and $T=D$. For the small bank angles involved, the sine of the bank angle and the angle (in radians) are considered equal. Rearranging Equation 1, and equating 1 radian to 57.3 degrees, the following results:

$$O=57.3[(a/b)/(L/D)] \quad \text{Equation 2}$$

The important parameter, L/D, may be estimated with comparative ease. Always numerically equal to the airplane's glide ratio, its peak value, (L/D)_{max}, equals best glide ratio and also frequently is tabulated (eg, Lan and Roskam, 1980). Representative values of (L/D)_{max} are listed in Table 3.

Table 3

Typical Airplane (L/D)_{max} Values

AIRPLANE	(L/D) _{max}	REFERENCE
Cessna 172 (Windmilling)	9.1	POH
Cessna Crusader (Feathered)	12.1	POH
Beech Baron (Feathered)	12.2	POH
DC-3	14.1	Lan & Ros.
Gulfstream II	15.2	Lan & Ros.
Jet Transports	16.4-19.4	Lan & Ros.

Range of Optimum Performance Bank Angles

The question of how much bank is best for performance can now be answered in the form of an expected range. Limiting values of bank angle from Equation 2 were estimated using typical a/b and L/D values tabulated above. Since it is unlikely an engine-out airplane will fly precisely at its (L/D)_{max} value, it was assumed $L/D = .9(L/D)_{max}$.

From Table 2, $.35 < (a/b) < .46$. From Table 3 (modified), $10.9 < (L/D) < 17.5$. Substituting into Equation 2, the optimum performance bank angle can be expected to range between approximately:

$$57.3(.35/17.5) = 1.1^\circ \quad \text{and} \quad 57.3(.46/10.9) = 2.4^\circ$$

Despite the approximations implicit in this analytical model, two important conclusions are clear:

1. In every case the optimum bank is likely to be much less than 5° , and
2. The less the performance margin, the smaller the optimum performance angle of bank.

Simulated Engine-out Wind Tunnel Experiments

A Lockheed S-3A "Viking" model of 12" span was tested in a low speed (100 fps) wind tunnel. The objective was to estimate the sideslip angle resulting from engine-out, wings level flight, and to study the relationship between slip angle and drag.

Given the a/b ratio of .38 (Table 2), it was found that a slip angle of 2.0° corresponded to $H/D=0.38$. With wings level and 2.0° slip angle, the parasite drag was 1.14 times its zero slip value, under conditions of approximately zero lift and induced drag. Hence, zero slip flight should reduce parasite drag by $(1.00-1.00/1.14)100=12.6\%$. Assuming conditions of flight were near $(L/D)_{max}$, where parasite drag equals half of total drag, zero slip total drag should be reduced about 6.1% compared to wings level.

Substituting $a/b=.38$ and $(L/D)=17 \times 0.9$ into Equation 2, the zero slip bank angle was estimated to be 1.4° . Assuming a linear relation between bank angle, slip angle and drag, banking 2.8° would produce a 2.0° slip into the live engine and produce drag equal to the wings level value. Banking the additional 2.2° to 5° should increase drag about $(2.2/1.4)6.1=9.6\%$ above the minimum, zero slip value for the S-3A.

Subsequently, wind tunnel tests were conducted using a 16" span Cessna Crusader (T303) model. Results were qualitatively similar to those described above, and also correlated with actual flight test data. Significant wind tunnel equipment upgrades are programmed in the near future, with the potential for substantially improved experimental precision.

The S-3A wind tunnel experiment and attendant assumptions yielded encouraging but imprecise data. Nevertheless, the promise of significant drag reduction, compared to that corresponding to the 5° bank, was tantalizing. It was noted that a given percentage change in drag was equivalent to either a thrust or weight change of like magnitude - under the most critical flight conditions.

Flight Test Experiments

The analytical model and wind tunnel experiments promised improved performance, with adequate control, at zero slip. Subsequently, flight tests were conducted in three airplanes, the Cessna Crusader, Piper Seminole, and Beech Baron. Test data confirmed the analytical and wind tunnel results.

A yaw string about three feet long was attached to the nose, where it could be seen clearly in order to establish zero slip flight. An effective precision bank indicator was fabricated by combining a common protractor, plumb bob, and bubble level. Mounted beneath the glare shield, the device allowed bank angle measurements to 1/2 degree precision or better. All experiments were conducted in smooth air.

Rates of climb, as a function of bank angle, were determined by measuring altitude change over two or three minute intervals at steady V_y . Constant power settings and base altitudes were utilized. Weight variations, with fuel consumed, were accounted for and results reduced to a common time/weight. Approximately 1/3 of the Crusader data was gathered at zero thrust, simulated engine-out conditions. The remainder, as well as all the Seminole and Baron data, were taken with a propeller feathered. Except for the Baron, the airplanes have counter-rotating propellers, hence no critical engine. Various bank angles, up to 7° - 10° were evaluated. Rate of climb predictions in the POH were carefully compared to observed values for the Crusader.

A summary of the experimental data is contained in Table 4. In Figure 3 the data are plotted using a least squares, linear regression.

Table 4

Summary of Engine-out Flight Test Results

FACTOR	UNITS	CESSNA CRUSADER	PIPER SEMINOLE	BEECH BARON 58
<u>(BASIC CHARACTERISTICS)</u>				
Max T.O. Wt	lbs	5150	3800	5400
Mid Test Wt	lbs	4930	3400	5050
Base D.A.	feet	3450	3350	5070
V _{mc} (POH)	KIAS	65	56	81 *
V _{lof}	KIAS	77	70	86
V _{yse}	KIAS	96	88	100
Zero Slip Bank (Equation 2 Est.)	Deg	2.2	2.4	2.0
<u>(FLIGHT TEST MEASUREMENTS)</u>				
Zero Slip Bank	Deg	1.5	2.1	2.7
Ball Defl (Z.S.)	-	.3	.4	.7
Max Bank Angle	Deg	10	7	8.5
Zero Rudder Bank	Deg	8	N.O.	7.5
ROC Chg(0° to ZS)	FPM	+42	+62	+105
ROC Chg(ZS to 5°)	FPM	-91	-92	-76
ROC Penalty	Ft/Min-Deg	-26	-32	-33
Corr. Coefficient	-	-.957	-.943	-.945
<u>(EQUIVALENCY CALCULATIONS {Zero Slip to 5°}) *</u>				
Weight Penalty	lbs	398	305	296
Weight Penalty	%	8.1	9.0	5.9
D.A. Penalty	feet	1850	1900	1170
Temp. Penalty	°C	15	16	10

* Left (critical) propeller feathered

FIGURE 3: RATE OF CLIMB VS ANGLE OF BANK

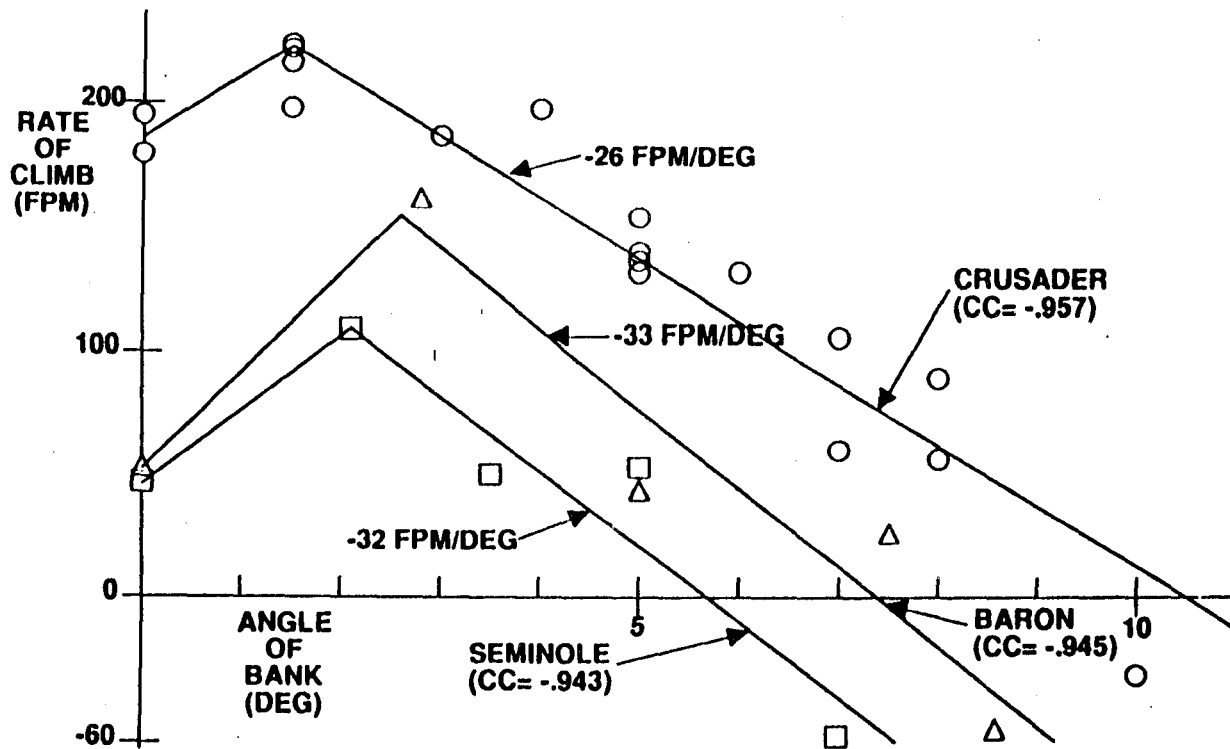

Table 4 and Figure 3 show flight test results. Zero slip bank angles and ball deflections proved significantly less than described in common references, such as those cited previously.

For the Crusader and Seminole, the actual zero slip bank angles were slightly lower than estimated using Equation 2. The reverse applied to the Baron's critical engine. The differences are probably explained by asymmetric disk loading ("P factor"). In critical engine operations, dimension "a" and resulting yaw is increased, while for other propeller airplanes (including counter rotating), it is reduced. For jets this factor would not apply.

High correlation coefficients lend credibility to the experimental flight techniques and the assumed linear relation between bank and drag. The sharp loss of climb performance, as bank exceeded the zero slip (ZS) value, was the most significant finding. Rate of climb degraded 26-33 feet per minute (FPM) per degree of bank in excess of the ZS value. The penalty for 5° bank ranged up to more than 90 FPM from optimum.

The bottom of Table 4 contains equivalency results derived from the respective POH. In comparing ZS and 5° bank performance, the effective penalty was equated to as much as a 9% weight or 1900 foot density altitude increase, except for the critical engine case. Since the latter required a larger ZS bank angle, the use of 5° imposed a somewhat reduced handicap.

Conclusions

Current multi-engine pilot education and training is handicapped by persistent misunderstandings concerning engine-out flying hazards and techniques to minimize them. In the low speed, low altitude engine-out environment, there exists three lethal hazards of comparable severity. These are loss of directional control, loss of climb performance, and loss of flying speed. Combined, they result in an annual average of 9 accidents and 10 fatal or serious injuries. Yet directional control receives virtually total emphasis in classroom and cockpit training, with insufficient regard to its influence on the ability to maintain altitude and/or flying speed.

Objective questioning of rated multi engine pilots and instructors proved that the relationships between control and performance are seldom understood. This apparently stems from the FAA Flight Training Handbook, as well as from other standard sources.

Analytical methods showed that the optimum performance angle of bank is neither 5° nor any other single value, but rather one dependent on the airplane, its weight, density altitude, and other minor factors. In marginal performance situations, when tolerance for error is least, it is at the minimum and far less than 5° .

Wind tunnel tests, although of limited scope, validated the theoretical model. Results suggested impressive performance gains, with adequate directional control, were available to the knowledgeable pilot.

Wind tunnel results suggested logical extension to actual test flights. Tests in three different airplanes yielded results consistent with the theory, the wind tunnel experiments, and each other.

Plotting rate of climb versus bank for each airplane produced "roof top" curves, with apex corresponding to optimum performance under zero slip (ZS) conditions. Banking beyond ZS incurred a substantial performance penalty in return for slightly reduced rudder pressure.

The experiments provided insight into critical engine operations and the design advantage of counter rotating

propellers. Directional control was no problem for the Crusader and Seminole, as the 30+ knots between Vmc and Vyse (Table 4) suggests. However, with full rudder, the Baron (critical engine operation) would not hold heading, at Vyse, with the slightest bank toward the inoperative left engine. Also, 8.5° right bank required full aileron.

Bank beyond 2S produced a slip toward the operating engine, increased rudder authority, and reduced rudder pressure. It was interesting to observe that zero rudder deflection was adequate to hold heading at 7.5° of bank in the Baron and 8° in the Crusader-at a very large performance penalty. Any greater bank required cross controlling with "top" rudder.

A yaw string of about 3' length was extremely sensitive, deflecting approximately 2" for each degree of bank. One ball width deflection, corresponding to 4-6° of bank, corresponded to approximately a 10" deflection.

At zero slip, the Crusader engine out rate of climb differed only an average of about 10 FPM from POH predictions. Figure 3 indicates that performance would have been substantially inferior to predictions at the 5° bank recommended by that POH. However, the POH fails to alert the pilot to this anomaly.

In summary, between zero bank and zero slip, both control and performance improved with bank. However, once the bank angle for zero slip was exceeded, performance deteriorated rapidly. Equivalent weight increase (or thrust decrease) handicaps of some

6-9% resulted from the popular 5° bank, and rate of climb was degraded by 76-92 FPM.

In addition to offering optimum performance, flight at zero sideslip may confer another safety benefit. Although beyond the scope of these experiments, the writer believes Berven (1980) was correct in asserting that zero slip flight also provides insurance against premature, and possibly asymmetrical, stall and violent roll characteristics.

The Flight Training Handbook and other references cited deserve timely revision. Replacement instructions are recommended as follows:

As soon as directional control is established and the airplane configured for climb, reduce the bank angle to that producing zero slip and best performance. (In the absence of specific guidance for zero slip, a bank of 2° or 1/2 ball deflection is suggested).

Engine-out instruction should be conducted regularly with a yaw string installed. Heavy weight, marginal power, minimum performance, worst case T/W conditions should be emphasized. Rather than adding weight, this can be accomplished simply by power reduction on the operating engine until best climb rate is barely positive.

In this manner, marginal T/W ratio simulation may be accomplished realistically and dramatically on any training flight. Concurrently, the optimum performance, zero slip bank

angle and ball position can be determined readily for any model (and engine, if appropriate). The advantage of determining zero slip ball deflection is that it can be reproduced readily under any lighting or visibility conditions, as well as in turning flight.

References

- Berven, L. (1980). Engine-out characteristics of multi-engine aircraft. Flight Instructor Bulletin No.29 (8/80), FAA Southern Region. Atlanta, GA: Federal Aviation Administration.
- Cessna Aircraft Company. (1981). Model T303 crusader information manual. Wichita, KS: Author.
- Federal Aviation Administration. (1980). Flight Training Handbook (AC 61-21A). Washington, DC: U.S. Government Printing Office.
- Kershner, W. (1985). The advanced pilot's flight manual (5th ed.). Ames, IA: The Iowa State University Press.
- Lan, C., & Roskam, J. (1981). Airplane aerodynamics and performance. (1st ed.). Ottawa, KS: Roskam Aviation and Engineering Corporation.
- Newton, D. (1987, November) Light-twin engine-out flying. Business and Commercial Aviation, p.69-75.
- Piper Aircraft Corporation. (1978). PA-44-180 seminole pilot's information Manual. Vero Beach, FL: Author.